

LX 550 – LX 650

POMPA PER VUOTO A PALETTE LUBRIFICATE

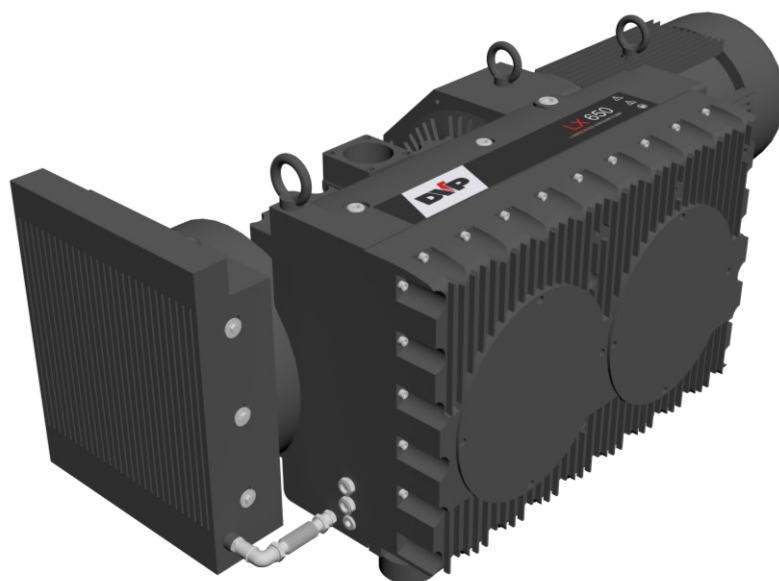

DATI TECNICI

		LX 550		LX 650	
CODICE		9603046		9603047	
FREQUENZA	Hz	50	60	50	60
PORTATA NOMINALE	m³/h	550	660	650	780
PRESSIONE FINALE TOTALE (Ass)	mbar –hPa	0,5		0,5	
Campo Di Lavoro In Continuo (Ass)	mbar –hPa	200 ÷ 0,5		200 ÷ 0,5	
POTENZA MOTORE	kW	15	18	15	18
CAPACITÀ OLIO (MIN - MAX)	dm³	16			
TIPO OLIO	Cod. DVP	SW100			
RUMOROSITÀ (UNI EN ISO 2151 – 3db)	dB (A)	82		83	
PESO	Kg	436		459	

CURVE

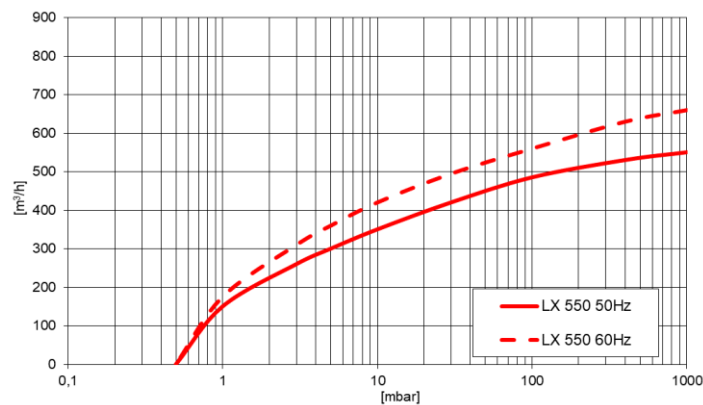
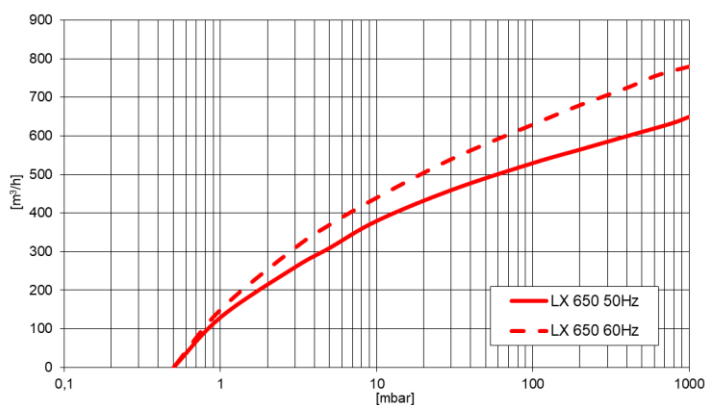

NOTA: Curve riferite alla pressione di aspirazione e temperatura 20°C (tolleranza ±10%)

LX 550 – LX 650

POMPA PER VUOTO A PALETTE LUBRIFICATE

DIMENSIONI

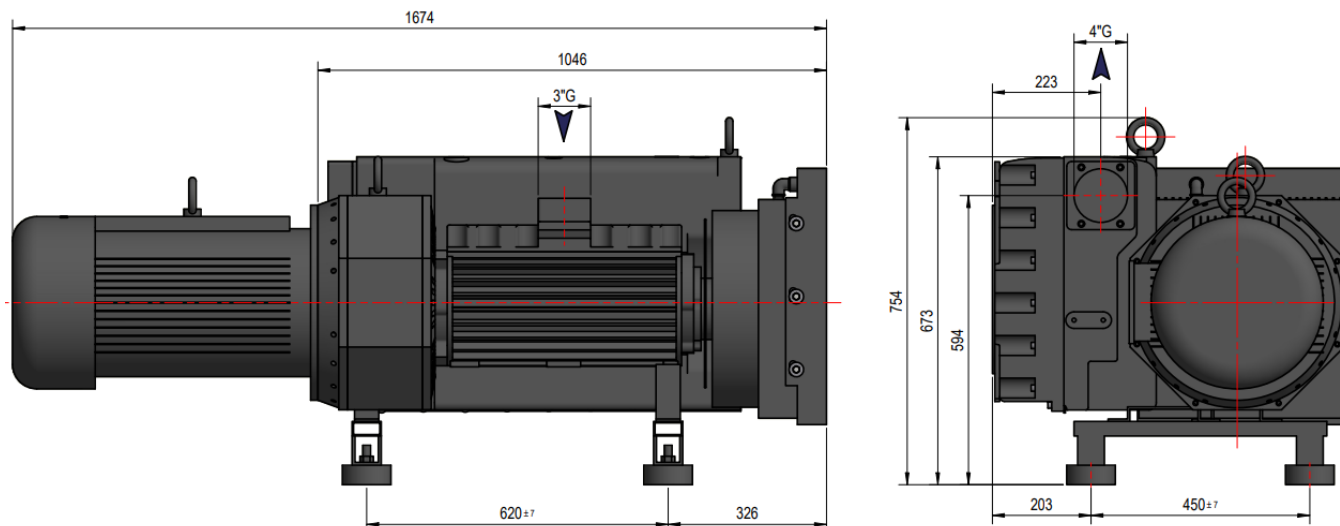

MOTORI

LX 550 [3 phase]

ID	POTENZA [kW]	TENSIONE	FREQUENZA	EFFICIENZA	RPM	
SR	15	Δ400/Y690	50	IE3	1465	
	18	Δ480/Y830	60	IE3	1758	
SG	18,5	Δ400/Y690	50	IE3	1470	UL
		Δ460/Y795	60		1765	

LX 650 [3 phase]

ID	POTENZA [kW]	TENSIONE	FREQUENZA	EFFICIENZA	RPM	
SR	15	Δ400/Y690	50	IE3	1465	
	18	Δ480/Y830	60	IE3	1758	
SG	18,5	Δ400/Y690	50	IE3	1470	UL
		Δ460/Y795	60		1765	

LX 550 – LX 650

POMPA PER VUOTO A PALETTE LUBRIFICATE

ACCESSORI

		Codice
1	FILTRO FCM	9001041
2	RACCORDO	2103126
3	RIDUZIONE	2001049
4	DADO	0202004
5	VUOTOMETRO	9009003
6	NIPPLES	2201019
7	CURVA	2101038
8	LIVELLOSTATO	9013021
9	RACCORDO A T	2106088
10	NIPPLES	2201019
11	MANOMETRO SIF	9014003
12	RIDUZIONE	2001012
13	TERMOSTATO	9019004

